



Operating Instructions and Parts Manual

**Industrial Pump Models:
SP-PP, SP-PHT, SP-CPVC, SP-PVDF,
SP-6600/6700 & SP-7600/7700
Series**

**Pump Package Models:
9400, 9420, 9430, 9500, 9510,
9710, 9760, 9900 & 9920 Series**

**Industrial Pump Motors:
SP-280P, SP-ENC, SP-A1, SP-A2
& SP-400 Series**

STANDARD PUMP INC.

1610 Satellite Blvd. Suite D, Duluth, Georgia 30097 USA
TOLL FREE 866-558-8611 • Phone 770-307-1003 • Fax 770-307-1009
e-mail: info@standardpump.com
www.standardpump.com



Operating Instructions and Parts Manual

TABLE OF CONTENTS	PAGE
General Safety Information.....	3
Centrifugal Drum Pumps	3
Motors.....	3
Motor Spare Parts	4
Drum Pump Tubes and Pump Packages	7
Operation & Maintenance	9
Pump Tube Spare Parts.....	11
Hazardous Duty / AtEx.....	14
Declarations of Conformity	16
Atex Declaration.....	18
Warranty.....	19

STANDARD PUMP INC.

1610 Satellite Blvd. Suite D, Duluth, Georgia 30097 USA
TOLL FREE 866-558-8611 • Phone 770-307-1003 • Fax 770-307-1009
e-mail: info@standardpump.com
www.standardpump.com

Standard Drum Pumps

Description

Standard's Drum Pumps are designed to transfer a variety of materials from 55 gallon drums and tanks. Standard Pump offers several different pumps, each designed for specific applications. Before operating, please confirm that the pump's materials of construction are suitable for the application.

Unpacking

Cartons should be handled with care to avoid damage from dropping, etc. After unpacking, inspect carefully for any damage that may have occurred during transit. Check for loose, damaged or missing parts.

General Safety Information

The responsibility for safe assembly, installation, and operation ultimately rests with the operator. Read and understand ALL safety precautions and operating instructions before operation. Careless pump operation can result in serious injury.

1. Before operating the pump, read and understand these operating instructions.
2. The operator should wear suitable protective clothing including the following: face mask, safety shield or goggles, gloves, apron, and safety shoes.
3. Before operating, verify the materials being pumped are compatible with the pump's "wetted components."

4. All Federal, State, and local safety codes should be followed.
5. Verify that the motor voltage corresponds to proper electrical supply.
6. Before plugging motor into power supply, make sure the motor switch is in the OFF position. For Air Motors ensure inlet valve is closed before attaching air line.
7. Before operation, confirm all pump connections are properly tightened.
8. First pump clean water in order to familiarize yourself with the pump's operation, flow rate, discharge pressure and motor speed.
9. Before starting the pump, confirm the discharge hose is securely fastened to the receiving vessel in order to prevent splashing.
10. Never leave pump unattended during operation.
11. Do not submerge the motor in any liquid.
12. When finished using the pump, flush the pump by pumping water or an appropriate cleaning solution. Do not use flammable or combustible cleaning solutions.
13. Never carry the motor by the power cord.
14. Never store pump in a container or drum. Always rinse pump thoroughly and hang on wall bracket or ensure pump tube is stored in an upright and vertical position.

⚠ WARNING: The speed control should not be used as the main ON/OFF switch. Using the speed control switch in this manner causes excessive wear to the potentiometer and may result in premature failure. The use of the speed control switch does not cut power to the motor and inadvertent activation could result in injury or death if the motor is activated when not properly attended and secured. (Only applies to SP-280P and SP-ENC Series)

⚠ WARNING: When pumping flammable or combustible products or operating in a hazardous duty environment, the SP-6600/6700 or SP-7600/7700 Series pump must be used in conjunction with an explosion proof motor. Please contact the factory or an authorized distributor with any questions regarding this matter.

Electric Drum Pump Motor Specifications

Model	Voltage	Amps	Watts	HP	Phase	Hz	Enclosure	Variable Speed	Hazardous Duty	Shipping Wt lbs (kg)
SP-410EX	115V	2	230	0.30	1	50-60	Hazardous Duty	N	Y	17 (7,7)
SP-420EX	230V	2.6	600	0.80	1	50-60	EXP (IP54)	N	AtEx	17 (7,7)
SP-430EX	115V	9.1	1000	1.30	1	50-60	Hazardous Duty	Y	Y	17 (7,7)
SP-440EX	230V	4.4	1000	1.30	1	50-60	EXP (IP55)	Y	AtEx	17 (7,7)
SP-280P*	110V	8.5	825	1	1	50-60	ODP (IP44)	N	N	9.0 (4,0)
SP-280P-V*	110V	8.5	825	1	1	50-60	ODP (IP44)	Y	N	9.0 (4,0)
SP-280P-2	220V	5	825	1	1	50-60	ODP (IP44)	N	N	9.0 (4,0)
SP-280P-2-V	220V	5	825	1	1	50-60	ODP (IP44)	Y	N	9.0 (4,0)
SP-280-2NL*	220V	5	825	1	1	50-60	ODP (IP44)	N	N	9.0 (4,0)
SP-280-2-VNL*	220V	5	825	1	1	50-60	ODP (IP44)	Y	N	9.0 (4,0)
SP-ENC*	110V	8.5	825	1	1	50-60	TEFC (IP54)	N	N	12.7 (5,7)
SP-ENC-V*	110V	8.5	825	1	1	50-60	TEFC (IP54)	Y	N	12.7 (5,7)
SP-ENC-2	220V	5	825	1	1	50-60	TEFC (IP54)	N	N	12.7 (5,7)
SP-ENC-2-V	220V	5	825	1	1	50-60	TEFC (IP54)	Y	N	12.7 (5,7)
SP-ENC-2NL*	220V	5	825	1	1	50-60	TEFC (IP54)	N	N	12.7 (5,7)
SP-ENC-2-VNL*	220V	5	825	1	1	50-60	TEFC (IP54)	Y	N	12.7 (5,7)

* The motor has thermal overload protection which stops the pump in case of overload. Immediately switching the motor off, position "0", and allowing the motor to cool down.
Warning: The motor automatically starts after cooling down, if the switch is left in position "1" (ON)

Air Drum Pump Motor Specification

Model	HP	Watts	Max Inlet Pressure	Min Hose	Max dBA	Airline Size Inches	Hazardous Duty	Air Consumption	Shipping Wt lbs (kg)
SP-A1	1/2	370	80 psi(5,5 bar)	3/8" (10 mm)	78	1/8" NPT	Y	27 CFM (13 L/min) @ 80 psi (5,5 bar)	2.7 (1,2)
SP-A2	3/4	560	100 psi(6,8 bar)	3/8" (10 mm)	87	1/4" NPT	Y	28 CFM (13,2 L/min) @ 90 psi (6,2 bar)	3.4 (1,5)
SP-A2TL (Trigger Lock)	3/4	560	100 psi(6,8 bar)	3/8" (10 mm)	87	1/4" NPT	Y	28 CFM (13,2 L/min) @ 90 psi (6,2 bar)	3.4 (1,5)
SP-A2P	3/4	560	100 psi(6,8 bar)	3/8" (10 mm)	87	1/4" NPT	Y	28 CFM (13,2 L/min) @ 90 psi (6,2 bar)	3.4 (1,5)

SP-280P Series Spare Parts List

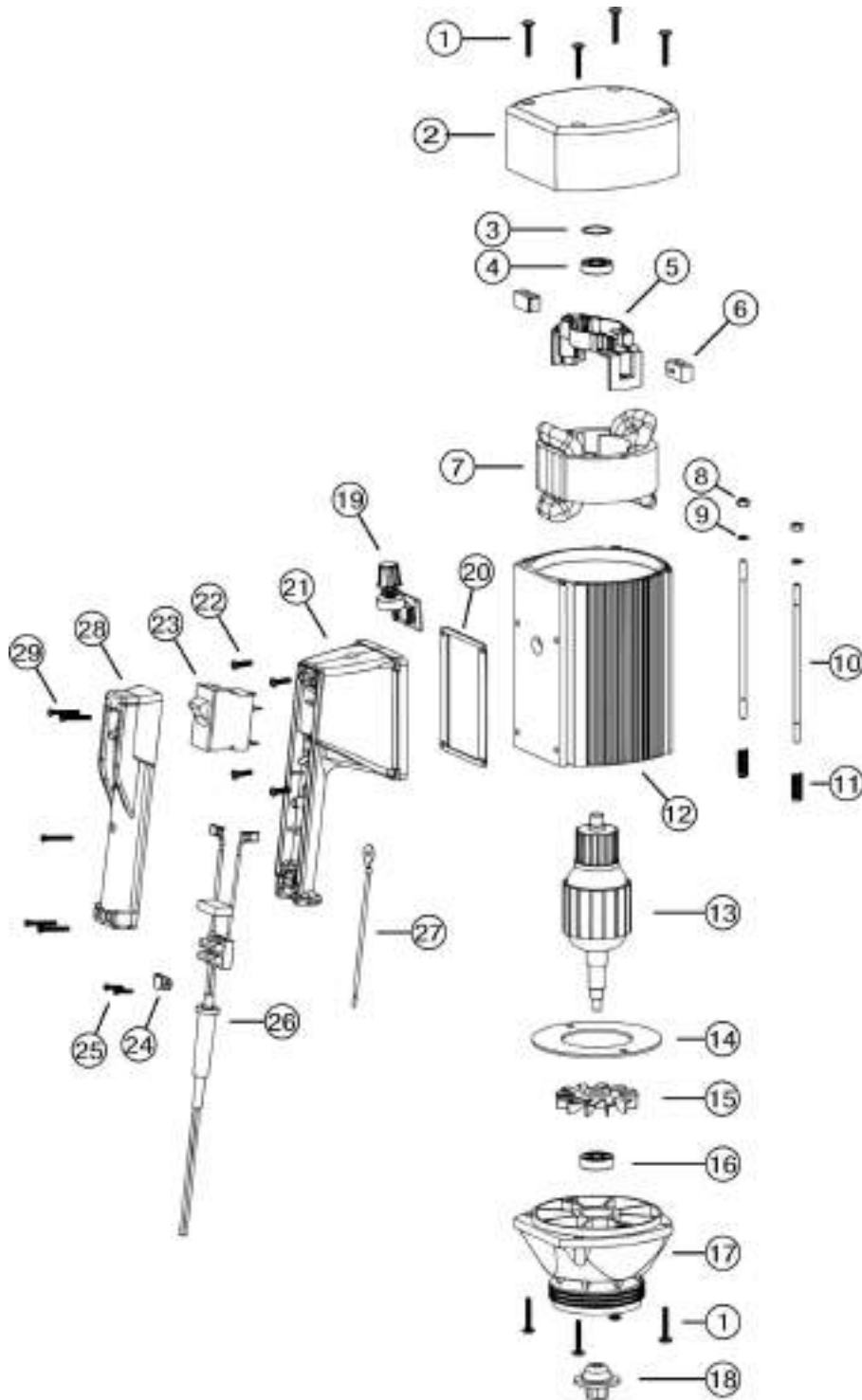

Ref #	Description	P/N	Qty
1	Screw, Motor Cover/Lower Housing	8130P	8
2	Motor Cover	8000	1
3	Wave Washer	8125	1
4	Bearing, Upper	8331	1
5	Brush Holder	8508	1
6	Carbon Brushes, 110/220V	8509*	2
7	Stator		1
	110V	8503	
	220V	8702	
8	Hexagon Nut	8448	2
9	Lock Washer	8071	2
10	Rod Connector	8506	2
11	Pressure Spring	8507	2
12	Motor Housing	8510P	1
13	Armature		1
	110V	8502	
	220V	8701	
14	Guide Disc	8504	1
15	Fan	8512	1
16	Bearing, Lower	8126	1
17	Lower Housing	8100	1
18	Motor Coupling	8333*	1
19	Speed Potentiometer		1
	110V	9803	
	220V	9804	
20	Gasket		1
	110V	8167	
	220V	8167LVR	
21	Switch Housing		1
	Fixed Speed	8001	
	Variable Speed	8010	
22	Screw, Switch Housing		4
	110V	8131	
	220V	8131LVR	
23	Overload Switch		1
	110V	8611	
	220V (w/ Low Voltage Release)	8704LVR	
	220V (w/o Low Voltage Release)	8704	
24	Cable Clamp	8001-1	1
25	Screw, Cable Clamp	8001-2	2
26	Power Cord		1
	110V	8360-KIT	
	220V	8705-KIT	
27	Earthing Lead	8183	1
28	Switch Cover	8002	1
29	Screw, Switch Cover	8221	5
N/A	Repair Kit* (Includes Items 6 & 18)		1
	110V - 220V	9055	

SP-ENC Series Spare Parts List

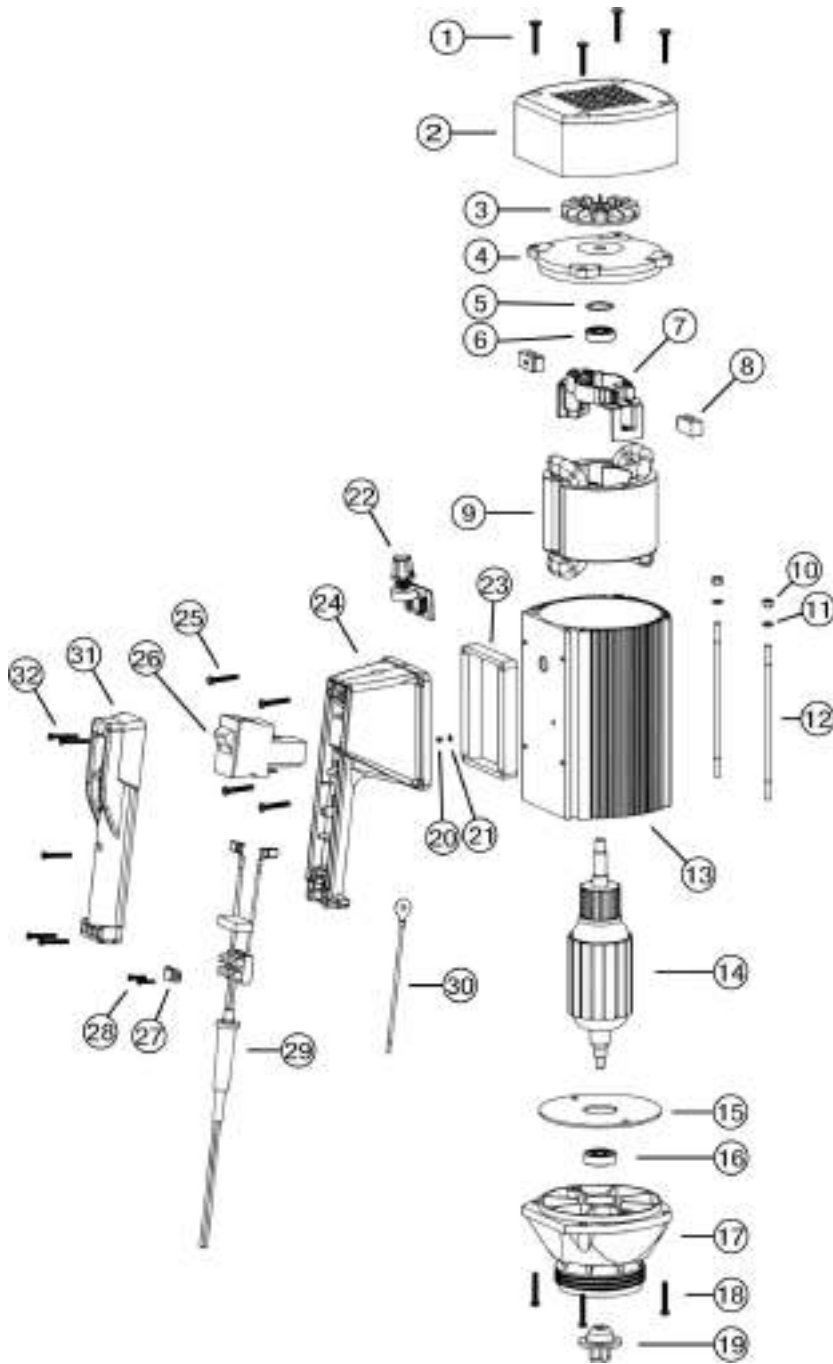

Ref #	Description	P/N	Qty
1	Screw, Motor Cover	3130	4
2	Motor Cover	3000	1
3	Fan	3512	1
4	Bearing Cover	3511	1
5	Wave Washer	8125	1
6	Bearing, Upper	8331	1
7	Brush Holder	8508	1
8	Carbon Brushes, 110/220V	8509*	2
9	Stator		1
	110V	3503	
	220V	3702	
10	Hexagon Nut	8448	2
11	Lock Washer	8071	2
12	Rod Connector	3703	2
13	Motor Housing	3510	1
14	Armature		1
	110V	3502	
	220V	3701	
15	Guide Disc	3504	1
16	Bearing, Lower	8126	1
17	Lower Housing	8100	1
18	Screw, Lower Housing	8130	4
19	Motor Coupling	8333*	1
20	Ground Screw	8162	1
21	Star Washer	8511	1
22	Speed Potentiometer		1
	110V	9803	
	220V	9804	
23	Gasket		1
	110V	8167	
	220V	8167LVR	
24	Switch Housing		1
	Fixed Speed	8001	
	Variable Speed	8010	
25	Screw, Switch Housing		4
	110V	8131	
	220V	8131LVR	
26	Overload Switch		1
	110V	8611	
	220V (w/ Low Voltage release)	8704LVR	
	220V (w/o Low Voltage release)	8704	
27	Cable Clamp	8001-1	1
28	Screw, Cable Clamp	8001-2	2
29	Power Cord		1
	110V	8360-KIT	
	220V	8705-KIT	
30	Earthing Lead	8183	1
31	Switch Cover	8002	1
32	Screw, Switch Cover	8221	5
N/A	Repair Kit* (Includes Items 8 & 19)		1
	110V - 220V	9055	

SP-A2 Series Spare Parts List

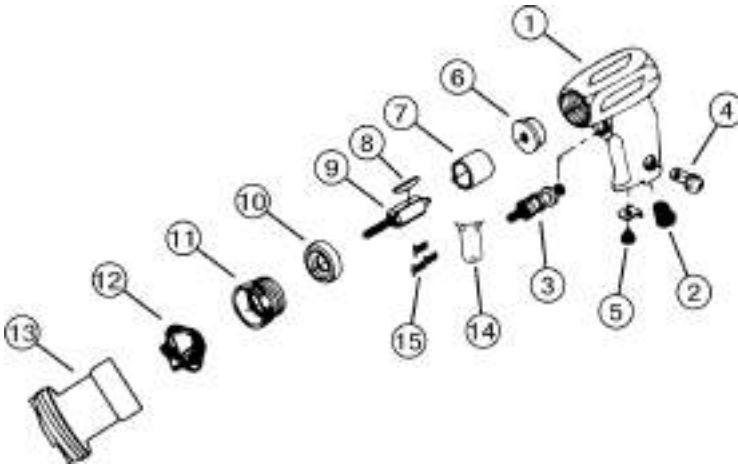

Ref. Number	Description	Part Number
1	Housing Assembly	317-A-A40
2	Inlet Bushing	317A-3B
3	Trigger Assembly	317A-A93
4	Regulator Assembly	317-A249
5	Muffler Kit	317A-AMK1
6	Rear End Plate Assembly	317A-A12
7	Cylinder	317-A3
8	Vanes (4 required)	317A-42-4
9	Rotor	317A-53
10	Front End Plate Assembly	317A-A11
11	Motor Lock Nut	317A-27
12	Motor Coupling	8333
13	Adaptor	3170
14	Trigger Plate (SP-A2P Only)	3176
15	Trigger Plate Screws (3 Required) (SP-A2P Only)	3177

Description: The SP-A2P air motor is equipped with a plate which permanently locks the trigger in the "ON" position. The speed of the motor can be adjusted by turning the speed regulator on the side of the motor handle between the "OFF" position and the "MAX" position.

Operation: Prior to connecting an air source to the air inlet of the SP-A2P, ensure that the speed regulator dial is in the "OFF" position (See Figure 1). Once the air source has been connected and the discharge hose of the pump tube is in its desired location, the speed regulator dial can be turned toward "MAX". Upon completion of the pumping process, the speed regulator dial should be returned to the "OFF" position. **⚠ Failure to do so can result in severe injury.**

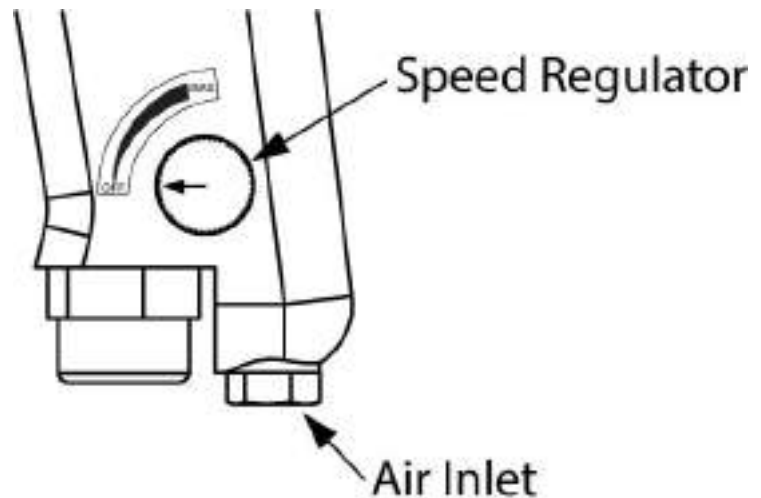
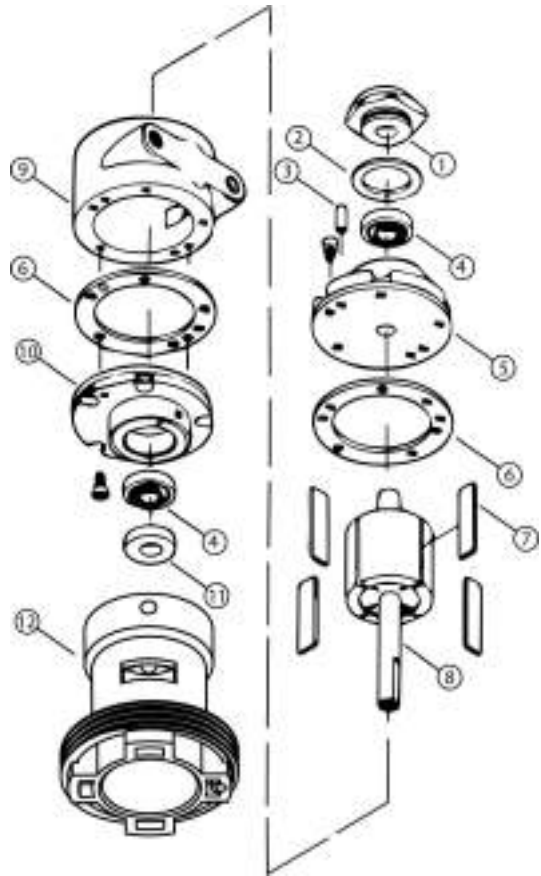

Figure 1

SP-A1 Spare Parts Lists

Ref. #	Description	P/N	Qty
-	Repair Kit* (Includes items 2,4,6,7 & 11)	SK285	
1	Dead End Cap	SAC228A	1
2*	Gasket	SAC229	1
3	Dowel Pin	SD324A	1
4*	Bearing	SAG549	2
5	Dead End Plate	SAC617	1
6*	Gasket	SAC527	2
7*	Vane	SAE893	4
8	Rotor Assembly	SAE896	1
9	Body	SAE899	1
10	Drive End Plate	SAC616	1
11*	Shaft Seal	SAC190A	1
12	Pump Tube Adapter	9007	1
-	Muffler (not shown)	SAF350	1
-*	Muffler Foam (not shown)	-	



Note: The only spare parts available for purchase are SK285 and 9007

DRUM PUMP SPECIFICATIONS

Model	Material of Construction	Maximum Liquid Temperature	Wetted Materials	Maximum Flow Rate	Discharge Pressure
SP-CPVC	CPVC	190° F (90° C)	CPVC, Carbon, Hastelloy C, PVDF, PTFE	35 gpm (132 l/min)	16 psi (1,1 bar)
SP-CPVC-HH	CPVC	190° F (90° C)	CPVC, Carbon, Hastelloy C, PVDF, PTFE	16 gpm (60 l/min)	32 psi (2,2 bar)
SP-PP	Polypropylene	130° F (55° C)	PP, Carbon, Hastelloy C, PTFE	35 gpm (132 l/min)	16 psi (1,1 bar)
SP-PP-HH	Polypropylene	130° F (55° C)	PP, Carbon, Hastelloy C, PTFE	16 gpm (60 l/min)	32 psi (2,2 bar)
SP-PHT	Polypropylene	175° F (80° C)	PP, Carbon, Hastelloy C, PTFE	35 gpm (132 l/min)	16 psi (1,1 bar)
SP-PHT-HH	Polypropylene	175° F (80° C)	PP, Carbon, Hastelloy C, PTFE	16 gpm (60 l/min)	32 psi (2,2 bar)
SP-PVDF	PVDF (Kynar®)	175° F (80° C)	PVDF, Carbon, Hastelloy C, PTFE	35 gpm (132 l/min)	16 psi (1,1 bar)
SP-PVDF-HH	PVDF (Kynar®)	175° F (80° C)	PVDF, Carbon, Hastelloy C, PTFE	16 gpm (60 l/min)	32 psi (2,2 bar)
*SP-7600	SS316	175° F (80° C)	SS316L, Carbon, PTFE	35 gpm (132 l/min)	16 psi (1,1 bar)
*SP-7700	SS316	175° F (80° C)	SS316L, Carbon, PTFE	16 gpm (60 l/min)	32 psi (2,2 bar)
*SP-6600	Aluminum	175° F (80° C)	Aluminum, Carbon, PTFE & SS316	35 gpm (132 l/min)	16 psi (1,1 bar)
*SP-6700	Aluminum	175° F (80° C)	Aluminum, Carbon, PTFE & SS316	16 gpm (60 l/min)	32 psi (2,2 bar)

 * When operating in Hazardous Duty applications a pump must be used in conjunction with an explosion proof motor or air motor.

Pump Package Specifications

Electric Motor Pump Packages

Model	HP	Voltage	Phase	Meter	Wetted Components	Immersion Length	Hose Length	Nozzle Material
9400	1	110V	1	No	Polypropylene, Carbon, Hastelloy C, PVC, Viton®, PTFE	39" (1000 mm)	6 ft. (1,83 meters)	Polypropylene
9401	1	220V	1	No	Polypropylene, Carbon, Hastelloy C, PVC, Viton®, PTFE	39" (1000 mm)	6 ft. (1,83 meters)	Polypropylene
9402	1	110V	1	No	Polypropylene, Carbon, Hastelloy C, PVC, Viton®, PTFE	47" (1200 mm)	6 ft. (1,83 meters)	Polypropylene
9403	1	220V	1	No	Polypropylene, Carbon, Hastelloy C, PVC, Viton®, PTFE	47" (1200 mm)	6 ft. (1,83 meters)	Polypropylene
9714	1	110V	1	No	SS316L, PTFE, Carbon, PVC, Viton	39" (1000 mm)	6 ft. (1,83 meters)	SS316
9715	1	220V	1	No	SS316L, PTFE, Carbon, PVC, Viton	39" (1000 mm)	6 ft. (1,83 meters)	SS316
9716	1	110V	1	No	SS316L, PTFE, Carbon, PVC, Viton	47" (1200 mm)	6 ft. (1,83 meters)	SS316
9717	1	220V	1	No	SS316L, PTFE, Carbon, PVC, Viton	47" (1200 mm)	6 ft. (1,83 meters)	SS316
9420	1	110V	1	No	PVDF, Carbon, Hastelloy C, XLPE, Viton®, PTFE	39" (1000 mm)	6 ft. (1,83 meters)	PVDF
9421	1	220V	1	No	PVDF, Carbon, Hastelloy C, XLPE, Viton®, PTFE	39" (1000 mm)	6 ft. (1,83 meters)	PVDF
9422	1	110V	1	No	PVDF, Carbon, Hastelloy C, XLPE, Viton®, PTFE	47" (1200 mm)	6 ft. (1,83 meters)	PVDF
9423	1	220V	1	No	PVDF, Carbon, Hastelloy C, XLPE, Viton®, PTFE	47" (1200 mm)	6 ft. (1,83 meters)	PVDF
9430	1	110V	1	No	CPVC, Polypropylene, Carbon, Hastelloy C, PVC, Viton®, PVDF, PTFE	39" (1000 mm)	6 ft. (1,83 meters)	Polypropylene
9431	1	220V	1	No	CPVC, Polypropylene, Carbon, Hastelloy C, PVC, Viton®, PVDF, PTFE	39" (1000 mm)	6 ft. (1,83 meters)	Polypropylene
9432	1	110V	1	No	CPVC, Polypropylene, Carbon, Hastelloy C, PVC, Viton®, PVDF, PTFE	47" (1200 mm)	6 ft. (1,83 meters)	Polypropylene
9433	1	220V	1	No	CPVC, Polypropylene, Carbon, Hastelloy C, PVC, Viton®, PVDF, PTFE	47" (1200 mm)	6 ft. (1,83 meters)	Polypropylene
9500	1	110V	1	Yes	Polypropylene, Carbon, Hastelloy C, PVC, Viton®, Ceramic, PVDF, Halar, PTFE	39" (1000 mm)	6 ft. (1,83 meters)	Polypropylene
9501	1	220V	1	Yes	Polypropylene, Carbon, Hastelloy C, PVC, Viton®, Ceramic, PVDF, Halar, PTFE	39" (1000 mm)	6 ft. (1,83 meters)	Polypropylene
9502	1	110V	1	Yes	Polypropylene, Carbon, Hastelloy C, PVC, Viton®, Ceramic, PVDF, Halar, PTFE	47" (1200 mm)	6 ft. (1,83 meters)	Polypropylene
9503	1	220V	1	Yes	Polypropylene, Carbon, Hastelloy C, PVC, Viton®, Ceramic, PVDF, Halar, PTFE	47" (1200 mm)	6 ft. (1,83 meters)	Polypropylene
9510	1	110V	1	Yes	PVDF, Carbon, Hastelloy C, XLPE, Viton®, Ceramic, Halar, PTFE	39" (1000 mm)	6 ft. (1,83 meters)	PVDF
9511	1	220V	1	Yes	PVDF, Carbon, Hastelloy C, XLPE, Viton®, Ceramic, Halar, PTFE	39" (1000 mm)	6 ft. (1,83 meters)	PVDF
9512	1	110V	1	Yes	PVDF, Carbon, Hastelloy C, XLPE, Viton®, Ceramic, Halar, PTFE	47" (1200 mm)	6 ft. (1,83 meters)	PVDF
9513	1	220V	1	Yes	PVDF, Carbon, Hastelloy C, XLPE, Viton®, Ceramic, Halar, PTFE	47" (1200 mm)	6 ft. (1,83 meters)	PVDF
9760	1	110V	1	No	Aluminum, Carbon, PTFE, SS316, Buna, PVC	39" (1000 mm)	6 ft. (1,83 meters)	Aluminum
9761	1	220V	1	No	Aluminum, Carbon, PTFE, SS316, Buna, PVC	39" (1000 mm)	6 ft. (1,83 meters)	Aluminum
9762	1	110V	1	No	Aluminum, Carbon, PTFE, SS316, Buna, PVC	47" (1200 mm)	6 ft. (1,83 meters)	Aluminum
9763	1	220V	1	No	Aluminum, Carbon, PTFE, SS316, Buna, PVC	47" (1200 mm)	6 ft. (1,83 meters)	Aluminum
9920	1	110V	1	No	SS316L, PTFE, Carbon, Viton, UHMWPE	39" (1000 mm)	6 ft. (1,83 meters)	SS316
9921	1	220V	1	No	SS316L, PTFE, Carbon, Viton, UHMWPE	39" (1000 mm)	6 ft. (1,83 meters)	SS316
9922	1	110V	1	No	SS316L, PTFE, Carbon, Viton, UHMWPE	47" (1200 mm)	6 ft. (1,83 meters)	SS316
9923	1	220V	1	No	SS316L, PTFE, Carbon, Viton, UHMWPE	47" (1200 mm)	6 ft. (1,83 meters)	SS316

Air Motor Pump Packages

Model	HP	Air Consumption	Meter	Wetted Components	Immersion Length	Hose Length	Nozzle Material
9904	0.5	27 CFM (13 L/sec) @ 80 psi (5,51 bar)	No	SS316L, PTFE, Carbon, Viton, UHMWPE	39" (1000 mm)	6 ft. (1,83 meters)	SS316
9905	0.75	28 CFM (13.2 L/sec) @ 90 psi (6,2 bar)	No	SS316L, PTFE, Carbon, Viton, UHMWPE	39" (1000 mm)	6 ft. (1,83 meters)	SS316
9906	0.5	27 CFM (13 L/sec) @ 80 psi (5,51 bar)	No	SS316L, PTFE, Carbon, Viton, UHMWPE	47" (1200 mm)	6 ft. (1,83 meters)	SS316
9907	0.75	28 CFM (13.2 L/sec) @ 90 psi (6,2 bar)	No	SS316L, PTFE, Carbon, Viton, UHMWPE	47" (1200 mm)	6 ft. (1,83 meters)	SS316
9764	0.75	28 CFM (13.2 L/sec) @ 90 psi (6,2 bar)	No	Aluminum, Carbon, PTFE, SS316, Buna, PVC	39" (1000 mm)	6 ft. (1,83 meters)	Aluminum
9765	0.75	28 CFM (13.2 L/sec) @ 90 psi (6,2 bar)	No	Aluminum, Carbon, PTFE, SS316, Buna, PVC	47" (1200 mm)	6 ft. (1,83 meters)	Aluminum

©Viton is a registered trademark of DuPont Dow Elastomers.

Assembly

1. Remove the pump and motor from packaging.
2. Inspect all contents for damage.
3. Couple the motor to the pump tube by using the Hand Wheel. (See figure 1).

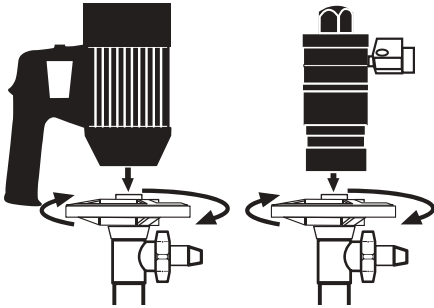

Figure 1

▲ WARNING When using an SP-A1 or SP-A2 Series motor, Standard Pump recommends the use of a Filter Lubricator Regulator (FLR) in order to ensure a moisture free supply of air to the motor.

▲ WARNING SP-A1 and SP-A2 Series motors must be lubricated daily to ensure proper functionality.

Operation

1. Once the pump is fully assembled and all connections are securely fastened, insert the pump into the drum or tank.
2. Turn the motor switch to the "ON" position or open air inlet valve.
3. If your package contains a flow meter (Package numbers 9500-9503 or 9510-9513) please reference the factory operating instructions which are located in your carton.
4. After use, clean the pump and store vertically.

Maintenance

DISASSEMBLY / CLEANING PROCEDURES

1. In order to clean a majority of the residue from the pump tube, immerse the pump into a 55 Gallon Drum of water. Allow the pump to circulate the water for 3 minutes.
2. For a more thorough cleaning remove the motor from the pump tube by loosening the hand wheel (see Figure 2).

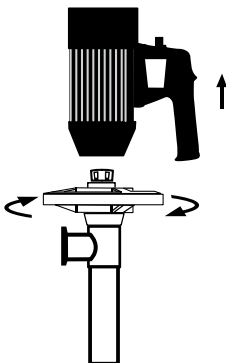

Figure 2

3. Remove the pump foot. (see Figure 3)

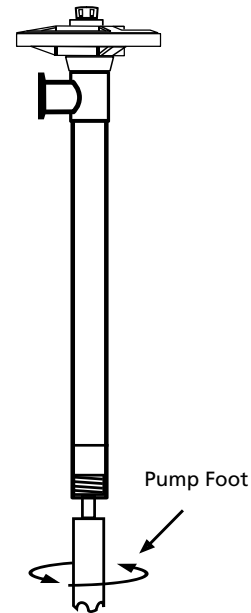

Figure 3

NOTE: Remove pump foot by turning clockwise.

4. While holding the drive shaft with pliers (factory suggests using grip-locks to avoid scarring shaft) remove the impeller by turning counter clockwise (see Figure 4).

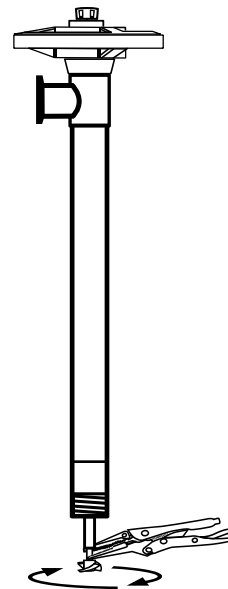

Figure 4

NOTE: Use grip lock pliers to hold shaft while removing impeller.

5. Remove the Pump Housing (see Figure 5).

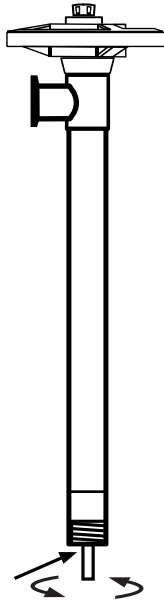

Figure 5

NOTE: Remove pump housing by turning clockwise.

6. For plastic and aluminum models, remove outer tube and inner tube from discharge housing by turning clockwise (see Figure 6).

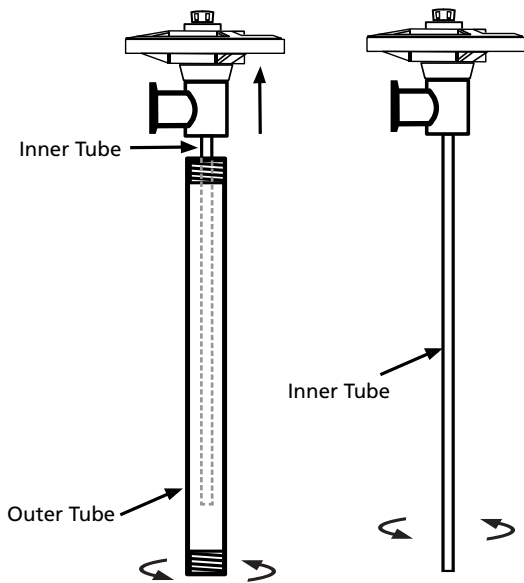

Figure 6

7. For stainless steel models (i.e. 7600-7700, 9714-9717 & 9904-9913), remove connection flange from inner/outer tube assembly by turning clockwise (see Figure 7).

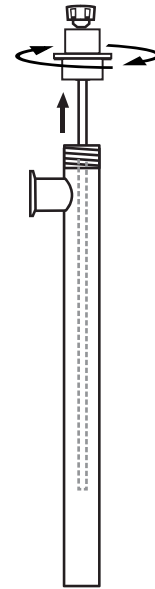

Figure 7

8. Remove pump coupling (P/N: 1004) from drive shaft by turning counterclockwise (see Figure 8). **NOTE:** Use grip-lock pliers to hold shaft while removing coupling.

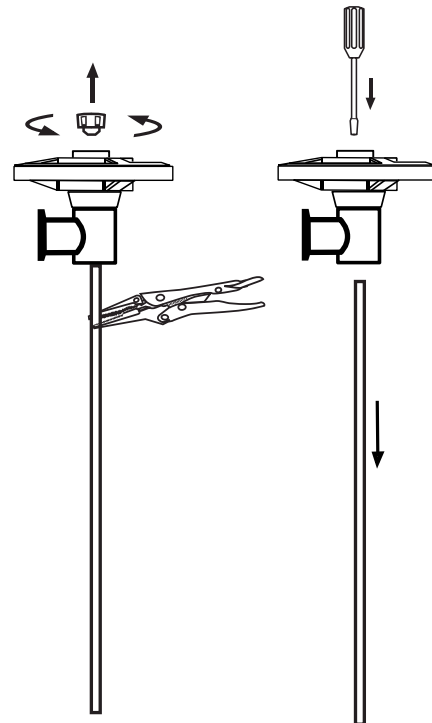

Figure 8

Figure 9

9. Pull drive shaft straight down removing it from the discharge housing or connection flange while inserting a screwdriver through bearing unit (P/N: 1038) (see Figure 9). **NOTE:** Ensure screwdriver is maintained inside bearing unit so spacer and seal are stationary and aligned properly for reassembly.

⚠ WARNING *When replacing the drive shaft in the bearing unit (PIN1038) durin reassembly, make sure the drive shaft is inserted through the spacer in between the bearings inside the bearing unit. Failure to do so could cause the bearing unit to prematurely fail.*

SP-PP, SP-PHT, SP-CPVC, SP-PVDF Series Spare Parts List

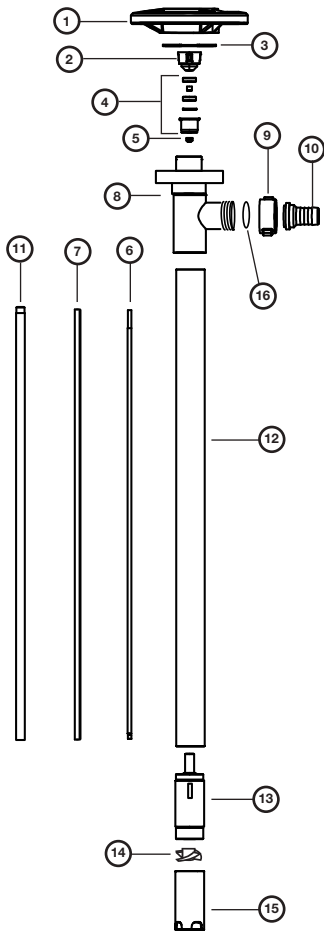

Ref. Number	Description	P/N for SP-PP	P/N for SP-PHT	P/N for SP-CPVC	P/N for SP-PVDF	Qty
1	Hand Wheel, Polypropylene	1842	1842	1842	1842	1
2	Pump Coupling, Nylon	1004*	1004*	1004*	1004*	1
3	Snap Ring, Steel	1508	1508	1508	1508	1
4	Bearing Unit Assembled – 2 each Viton shielded bearings, spacer, snap ring, bearing can	1038*	1038*	1038*	1038*	1
5	V-Seal					1
	Viton®	1000	-	-	-	
	PTFE	-	4000	4000	4000	
6	Drive Shaft, Hastelloy					1
	27" (700 mm)	1543	1543	1543	1543	
	39" (1000 mm)	1544	1544	1544	1544	
	47" (1200 mm)	1545	1545	1545	1545	
	50" (1270 mm)	1549	1549	1549	1549	
	60" (1500 mm)	1546	1546	1546	1546	
	72" (1800 mm)	1547	1547	1547	1547	
7	Guide Sleeve, PTFE					1
	27" (700 mm)	1516	1516	1516	1516	
	39" (1000 mm), 47" (1200 mm), 50" (1270 mm)	1514	1514	1514	1514	
	60" (1500 mm), 72" (1800 mm)	1661	1661	1661	1661	
8	Discharge Housing	1028	6028	5028	4028	1
9	Wing Nut	1106	6106	5106	4106	1
10	Hose Barb					1
	.75" (19 mm)	1051	6051	5051	4051	
	1" (25 mm)	1082	6082	5082	4082	
11	Inner Tube					1
	27" (700 mm)	1600	6600	5600	4600	
	39" (1000 mm)	1601	6601	5601	4601	
	47" (1200 mm)	1602	6602	5602	4602	
	50" (1270 mm)	1623	6623	5623	4623	
	60" (1500 mm)	1615	6615	5615	4615	
	72" (1800 mm)	1616	6616	5616	4618	
12	Outer Tube					1
	27" (700 mm)	1604	6604	5604	4604	
	39" (1000 mm)	1603	6603	5603	4603	
	47" (1200 mm)	1605	6605	5605	4605	
	50" (1270 mm)	1624	6624	5624	4622	
	60" (1500 mm)	1617	6617	5617	4617	
	72" (1800 mm)	1618	6618	5618	4619	
13	Pump Housing (Includes Carbon Bushing)	1524*	6524*	5524*	4607*	1
14	Rotor/Impeller					1
	High Volume Rotor	1608*	6608*	5608*	4608*	
	High Pressure Impeller	4608HH	4608HH	4608HH	4608HH	
15	Pump Foot					1
	High Volume	1609*	6609*	5609*	4609*	
	High Pressure	1609HH	6609HH	5609HH	4609HH	
16	O-Ring, Viton®	-	6695	-	-	1
n/a	Repair Kit (*Includes Items 2, 4, 13, 14 & 16)	9050	9053	9052	9051	1



SP-PP, SP-PHT, SP-CPVC, SP-PVDF pumps should not be used to pump flammables.

©Viton is a registered trademark of DuPont Dow Elastomers.

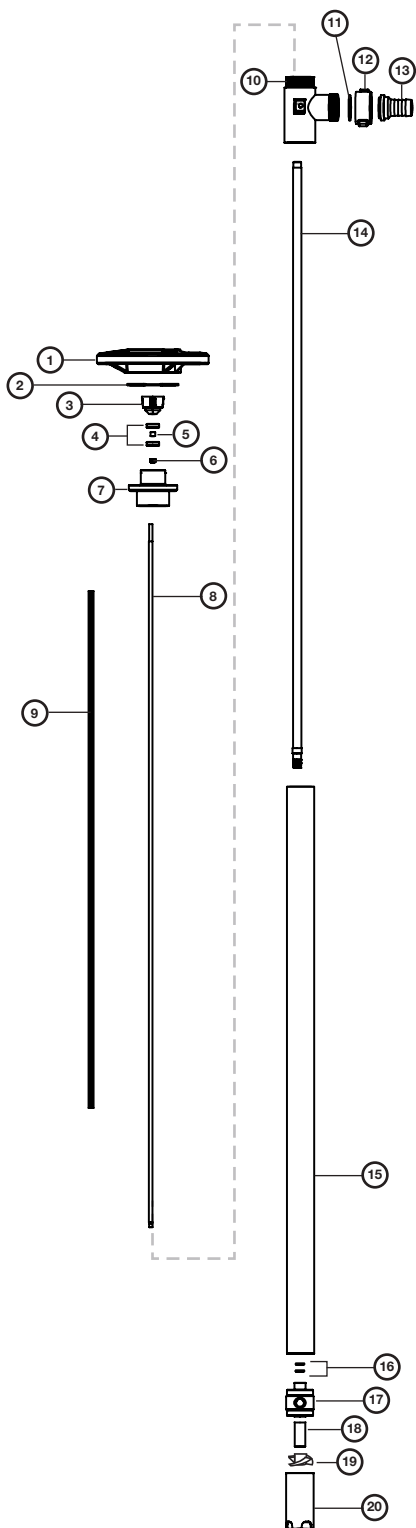

SP-6600 & 6700 Spare Parts List



Ref. Number	Description	P/N	Qty
1	Handwheel, Polypropylene	1842	1
2	Snap Ring, Steel	1508	1
3	Pump Coupling, Nylon	*1004	1
4	Bearing, Viton Shielded	*1038-2	2
5	Bearing Spacer, SS316L	*8838-4	1
6	V Seal, PTFE	4000	1
7	Connection Flange, AL 6061	6650	1
8	Drive Shaft, SS316L		1
	27" (700mm)	6661	
	39" (1000mm)	6662	
	47" (1200mm)	6663	
	60" (1500mm)	6664	
	72" (1800mm)	6665	
9	Guide Sleeve, PTFE		1
	27", 39", 47" (700mm, 1000mm, 1200mm)	7659	
	60", 72" (1500mm), 1800mm)	7660	
10	Discharge Housing, AL 6061	6651	1
11	Seal, PTFE	*2195	1
12	Knurled Nut, AL 6061	6656	1
13	Hose Barb, AL 6061		1
	Hose Barb, 1", (19mm)	6657	
	Hose Barb, 3/4" (25mm)	6658	
14	Inner Tube, AL 6061		1
	27" (700mm)	6670	
	39" (1000mm)	6671	
	47" (1200mm)	6672	
	60" (1500mm)	6673	
	72" (1800mm)	6674	
15	Outer Tube, AL 6061		1
	27" (700mm)	6680	
	39" (1000mm)	6681	
	47" (1200mm)	6682	
	60" (1500mm)	6683	
	72" (1800mm)	6684	
16	O-Ring, Viton	7655	2
17	Pump Housing, AL 6061	6685	1
18	Bushing, Carbon Graphite	*7606	1
19	Rotor/Impeller, PTFE		1
	High Volume Rotor (6600 Series)	*7706	
	High Pressure Impeller (6700 Series)	4608HH	
20	Pump Foot, AL 6061		1
	High Volume (6600 Series)	6686	
	High Pressure (6700 Series)	6786	
n/a	Repair Kit (*Includes Items 3, 4, 5, 11, 18, 19)	7054	1



When pumping flammable/combustible liquids, this pump must be used in conjunction with an explosion proof motor.

©Viton is a registered trademark of DuPont Dow Elastomers.

SP-7600 & 7700 Spare Parts List

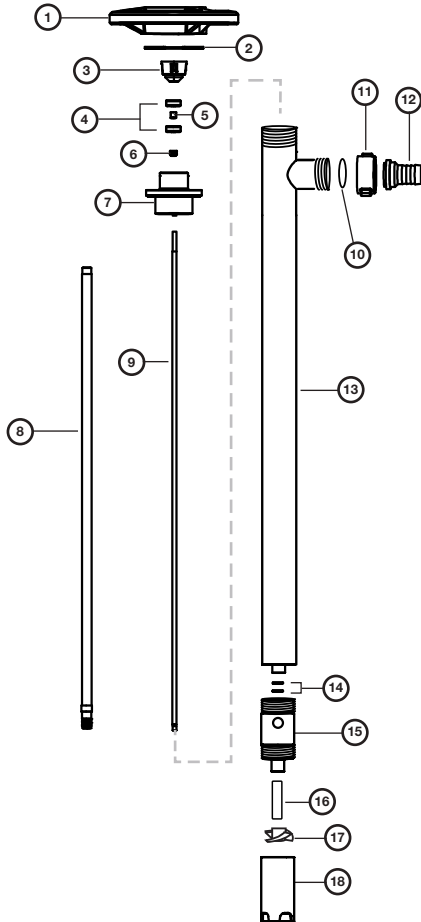

Ref. Number	Description	P/N for SP-SS	Qty
1	Hand Wheel, PP	1842	1
2	Snap Ring, Steel	1508	1
3	Pump Coupling, Nylon	*1004	1
4	Bearing, Viton Shielded	*1038-2	2
5	Bearing Spacer, SS316L	*8838-4	1
6	Secondary Seal, PTFE	4000	1
7	Connection Flange, SS316L	8602	1
8	Guide Sleeve		
	27"/39"/47" (1000/1200 mm)	7659	1
	60"/72" (1500/1800 mm)	7660	1
9	Drive Shaft, SS316L		1
	27" (700 mm)	8605	
	39" (1000 mm)	8606	
	47" (1200 mm)	8607	
	60" (1500 mm)	8608	
	72" (1800 mm)	8609	
10	O-Ring, PTFE	*2195	1
11	Knurled Nut, SS316L	7656	1
12	Hose Barb, SS316L		1
	1" Hose Barb	7657	
	3/4" Hose Barb	7658	
13	Inner/Outer Tube Assembly, SS316L		1
	27" (700 mm)	7650	
	39" (1000 mm)	7651	
	47" (1200 mm)	7652	
	60" (1500 mm)	7653	
	72" (1800 mm)	7654	
14	O-Ring, Viton	7655	2
15	Pump Housing, SS316L	7824	1
16	Bushing, Carbon Graphite	*7606	1
17	Rotor/Impeller, PTFE		1
	High Volume Rotor (7600 Series)	*7706	
	High Pressure Impeller (7700 Series)	4608HH	
18	Pump Foot, SS316L		1
	High Volume (7600 Series)	8826	
	High Pressure (7700 Series)	8926	
n/a	Repair Kit (*Includes Items 3, 4, 5, 10, 16, 17)	7054	1
n/a	Ground Wire Set, includes (1) 10 ft. lengths, (2) 6 ft. length, and (1) 1 ft. length.	9003	1



When pumping flammable/combustible liquids, this pump must be used in conjunction with an explosion proof motor.

©Viton is a registered trademark of DuPont Dow Elastomers.

Hazardous Duty Operation

▲ WARNING *When pumping flammable or combustible products or operating in a hazardous duty environment an SP-6600/6700 or SP-7600/7700 Series pump must be used in conjunction with an explosion proof motor. Please contact the factory or an authorized distributor with any questions regarding this matter.*

SP-420 EX, SP-440EX & SP-A1

When operating in Hazardous Duty applications, the SP-420EX, SP-440EX or SP-A1 must be used in conjunction with an SP-7600/7700 or SP-6600/6700 Series pump and properly bonded and grounded. Refer to the Motor specification chart for motor information.

Special Conditions for Safety Use



- Only for conductive liquids (gases groups IIA and IIB).
- The flashpoint for the flammable media shall be 50°C higher than the maximum temperature T4 (135°C).
- The SP-6600/6700 version may not be used in an area where rusty particles or rusty iron is present.
- The tube shall regularly be inspected for damage and corrosion, If there is any damage or corrosion, the equipment and the tube shall be taken out of service.
- The grounding clamp and wire on the pump shall be connected to the liquid container before and after pump start.
- The pumps must not be exposed to pumping hard solid particles which can create sparks.
- Inspect, maintain and repair equipment in accordance with the operating instructions.
- The pump is only for hand held operation and may not be run dry.
- The SP-6600/6700 version may only be used with the PTFE impeller parts no. 7706 and 4608HH.

Drum Pump Installation SP-410EX & SP-430EX

- Install the Pump and Static Protection Kit as described in Figure 6 on page 12.
- Connect Ground Wire assembly to earth ground using supplied clamp.
- Connect Ground Wire between drum and earth ground.
- Connect Ground Wire between receiving container and earth ground (or use bonding wire to connect to drum).

▲ CAUTION *Check electrical continuity of all components before pumping. All should be one (1) ohm or less.*

Operation and Safety Guidelines

- Use only metallic pump tubes with explosion proof motors to transfer flammable or combustible liquids.
- Area for use must comply with NFPA 30 guidelines for safe storage and use of flammable and combustible liquids.
- All containers and other equipment must be metal and grounded.
- Follow NGPA 77 guidelines for control of static electricity.
- Avoid splashing. Splash filling can create static electricity and is extremely hazardous.
- Fluid velocity must be 3 feet/second (0.91 meters/second) maximum 7 GPM in 1" hose (26.5 LPM in 25 mm hose).

Use Of Air Motors In Hazardous Atmospheres SP-A1 Series & SP-A2 Series

At the present time, there are no known standards governing the operation of air motors in hazardous atmospheres. However, there are several points regarding the safety of air motors.

First of all, an air motor is not a source of electric sparks. However, it is possible that an article which is not part of the air motor (e.g., wrenches, hammers, etc.) could create a spark by sharply impacting a cast iron or aluminum case or the steel shaft of the air motor. (Note that electric motor enclosures

for both class I and II hazardous locations can be made of "...iron, steel, copper, bronze, or aluminum..." (UL 674, Electric Motors and Generators – Hazardous Locations, June 23, 1989; paragraph 4.2, page 6). Second, an air motor housing is not designed to contain an internal explosion as is an explosion-proof electric motor. The only possible internal source of ignition in an air motor is a contact between the station housing components and the rotating elements that might create a spark. The likelihood of this occurring is reduced by the fact that the contact must be made at precisely the same time as a flammable or explosive gas is introduced into the air motor in a sufficient quantity to achieve a flammable or explosive mixture while overcoming the positive pressure of the driving gas. In other words, although highly improbable, an internal explosion in an air motor is possible. Finally, an air motor is designed to be operated by compressed air, the expansion of which in normal operation creates a cooling effect. As a result, the temperature of the air motor will not exceed the height of the temperatures of the surrounding atmosphere or the air delivered to the inlet.

We do not guarantee the safety of every application, but to ensure the safe operation of an air motor in your application, always follow the product direction and consult with a qualified engineer. (Source: Gast Manufacturing, Air Motors Handbook, page 2) Note: This statement is only applicable in North America.

▲ WARNING *When using an SP-A1 or SP-A2 Series motor, Standard Pump recommends the use of a Filter Lubricator Regulator (FLR) in order to ensure a moisture free supply of air to the motor.*

▲ WARNING *SP-A1 and SP-A2 Series motors must be lubricated daily to ensure proper functionality*

Grounding Procedures

⚠ WARNING *Transferring of flammables or use in hazardous duty. Bonding is an electrical connection between a primary metal vessel and a metal receiving vessel. See schematic.*

Grounding is an electrical connection between a metal vessel, pump, motor and a constant ground; i.e. a metal rod driven into the earth.

Bonding and grounding are required when pumping flammable materials or in hazardous duty environments. Failure to bond and ground properly can cause a discharge of static electricity resulting in fire, injury or death. Follow NFPA 77 and 30 procedures at all times. If in doubt, do not start pump! Be sure bonding and grounding wires are secure before starting operation. (Ground and bond wires must have less than one ohm resistance for safe usage. Check continuity

before starting). Always check with a safety engineer when any question arises and periodically check safety procedures with a safety engineer.

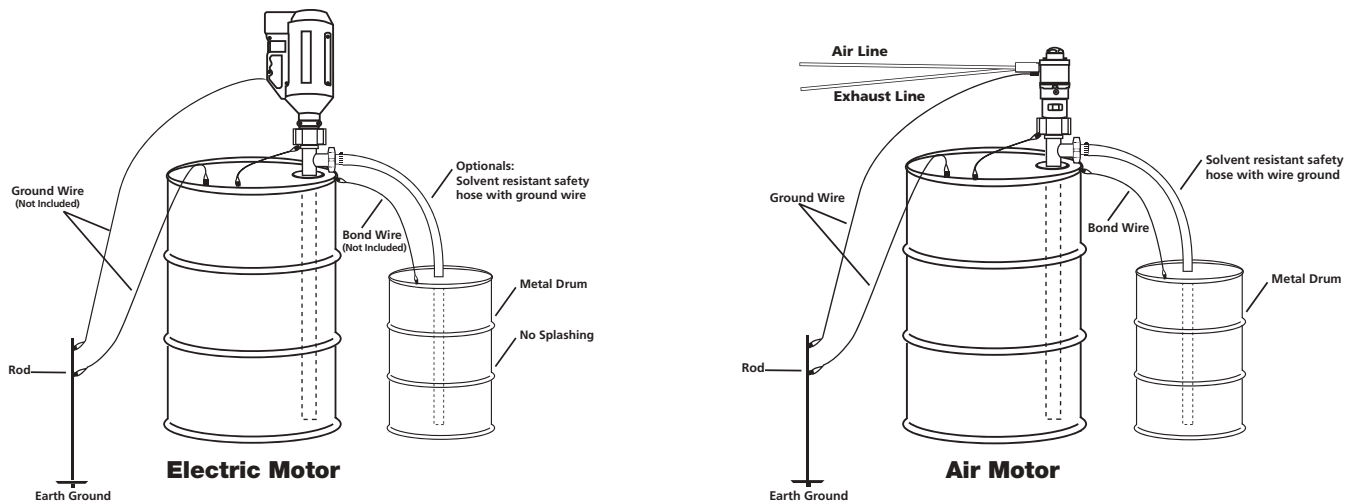

Figure 6 - Static Protection Kit

North America Declaration of Conformity

We here with declare that the construction type

Designation: **SP-280P**
 SP-280P-V
 SP-ENC
 SP-ENC-V

Machine type: Electric Motors for drum pumps

Item No: **SP-280P**
 SP-280P-V
 SP-ENC
 SP-ENC-V

In the form as delivered by us complies with following applicable regulations:

Conforms to UL STD 1004-1
Certified to CSA STD C22.2 No. 100
ETL Control number 5003012



Standard Pump, Inc.
Duluth, GA USA

Official responsible for documentation:
1 FEB 2016

Chris Murphy

Christopher Murphy
Director of Operations

EC Declaration of Conformity

We herewith declare that the construction type

Designation:	SP-280P-2 SP-280P-2-V SP-ENC-2 SP-ENC-2-V	SP-280P-2-NL SP-280P-2-V-NL SP-ENC-2-NL SP-ENC-2-V-NL
--------------	--	--

Machine type: Electric Motors for drum pumps

Item No:	SP-280P-2 SP-280P-2-V SP-ENC-2 SP-ENC-2-V	SP-280P-2-NL SP-280P-2-V-NL SP-ENC-2-NL SP-ENC-2-V-NL
----------	--	--

In the form as delivered by us complies with following applicable regulations:

Machine Safety	2006/42/EC
Low Voltage Equipment	2014/35/EU
Electromagnetic Compatibility	2014/30/EU
RoHS Directive	2011/65/EU

Applied Harmonized Standards:

EN ISO 12100-1, -2	EN 60204-1
--------------------	------------

EC official responsible for documentation:

24 AUG 2015

Date

Standard Pump, Inc.
Duluth, GA USA



Christopher Murphy
Director of Operations



Standard Pump Europe A/S
Rønnekrogen 2
DK-3400 Hillerød
Denmark
Phone: + 45 70 23 21 00
Fax: + 45 70 23 56 55
info@standard-europe.eu

EU-Conformity Declaration ATEX 2014/34/EU

We herewith declare that the products:

Model name: SP-6600/6700, SP-7600/7700, SP-8600/8700 and SP-8850/8950
Model design: All versions

Technical data: Equipment group II, Category 2G and 3G
Marking: EX II 2G c IIB T4
Liquid temperature: Max. 40°C
Ambient temperature: +5°C to +40° C

Confirms with the relevant EC Directive: Directive 2014/34/EU for equipment and protective systems intended for use in potentially explosive atmospheres (ATEX).

Applied harmonized standards: EN 13463-1:2009
EN 13463-5:2011

In accordance with appendix VIII of 2014/34/EU the documents are stored by the notified body no. 0396:

Danish Technological Institute
Kongsvang Allé 29
DK-8000 Århus C
File no / Certificate no.: DTI 13.0022X – ver.03

The protection of the pump against abnormal working situations has to be insured by user according to the manual.

Hillerød, January 15th. 2018

Standard Pump Europe A/S

Hans-Peder Jensen
Technical Director

WARRANTY

Three year limited warranty

Standard Pump, Inc. warrants, subject to the conditions below, through either Standard Pump, Inc., its subsidiaries, or its authorized distributors, to repair or replace free of charge, including labor, any part of this equipment which fails within **three years** of delivery of the product to the end user. Such failure must have occurred because of defect in material or workmanship and not as a result of operation of the equipment other than in accordance with the instructions given in this material. Specific exceptions include:

- Consumable items such as motor brushes, bearings, couplings and impellers. (Motor brushes typically have a life span of approximately 250 hours. This will vary with the manner in which the motor is used)

Conditions of exceptions include:

- Equipment must be returned by prepaid carriage to Standard Pump, Inc., its subsidiary or authorized distributor.
- All repairs, modifications must have been made by or with express written permission by Standard Pump, Inc., its subsidiary or authorized distributor.
- Equipment which have been abused, misused, or subject to malicious or accidental damage or electrical surge are excluded.

Warranties purporting to be on behalf of Standard Pump, Inc. made by any person, including representatives of Standard Pump, Inc, its subsidiaries, or its distributors, which do not fall within the terms of this warranty shall not be binding upon Standard Pump, Inc. unless expressly approved in writing by a Director or Manager of Standard Pump, Inc. Information for returning pumps Equipment which has been contaminated with, or exposed to, bodily fluids, toxic chemicals or any other substance hazardous to health must be decontaminated before it is returned to Standard Pump, Inc, or its distributor. A returned goods authorization number (RGA #) issued by Standard Pump, Inc., its subsidiary or authorized distributor, must be included with the returned equipment. The RGA # is required if the equipment has been used. If the equipment has been used, the fluids that have been in contact with the pump and the cleaning procedure must be specified along with a statement that the equipment has been decontaminated.

STANDARD PUMP

1610 Satellite Blvd. Suite D., Duluth, Georgia 30097 USA
TOLL FREE 866-558-8611 • Phone 770-307-1003 • Fax 770-307-1009

info@standardpump.com

www.standardpump.com

STANDARD PUMP EUROPE A/S

Ronnekrogen 2, DK-3400 Hillerod, Denmark
Phone +45 70 23 21 00 • Fax +45 70 23 56 55

info@standard-europe.eu

STANDARD
Pump